

ORIGINAL INSTRUCTIONS

OPERATING & MAINTENANCE MANUAL



SPACE HEATERS

IP110

Diesel Indirect Fired Space Heater

Not for domestic use - Space Heating Only

Made in Italy for:

Spitwater Australia Pty Ltd T/A Ottico Equipment

953 Metry Street, Albury NSW 2640 Australia

spitwater.com.au



CREATORS OF



WARNING: Read and understand this instruction manual before operating this unit and retain for future reference. Failure to follow operating, safety and maintenance instructions outlined in this manual releases the manufacturer from any responsibility for any accidents or damage incurred and may render any warranty void.

INTRODUCTION

Spitwater Australia is proudly Australian owned and operated since 1982. Our promise is to provide our customers with superior quality portable industrial heaters built to the highest of standards that will see many years of reliable service.

The JETFIRE range of portable industrial heaters are designed to give safe, efficient and reliable service when the correct operating and safety instructions are followed, and proper attention is given to all required maintenance procedures in order to maintain the unit in peak operating condition.

This manual provides the up to date information necessary for the user to operate the unit and carry out regular inspection and maintenance.

Please note that the information given within this manual may be subject to revision in compliance with Spitwater Australia's policy of continual improvement.

The JETFIRE range of heaters should only be used in the manner and purpose for which they were intended and in accordance with the recommendations and safety precautions detailed in this manual and in operating instructions and stickers on the unit itself.

All JETFIRE heaters undergo rigorous safety and operational tests before being dispatched into the marketplace however it is still imperative that prior to used, all operators have read and understood all information and instructions provided and are aware of possible hazards.

GENERAL DESCRIPTION & INTENDED USE

JETFIRE Heaters are specifically designed to solve all problems relating to heating drying and desiccating in commercial and industrial applications. Some examples of applications are in warehouse and factory heating, animal husbandry and greenhouse applications.

SPARE PARTS, ACCESSORIES AND AFTER SALES SERVICE

Spitwater has an extensive range of spare parts and accessories to suit all your heating needs. For spare parts, accessories and service please contact **1800 SPITWATER (1800 774 892)** and to view Spitwater's extensive range of JETFIRE industrial heaters online visit www.spitwater.com.au

TECHNICAL SPECIFICATIONS			IP 110	
			I S	II S
Combustion			Indirect	
Max heating output	Hi	[kW]	75.06	110.02
		[kcal/h]	64553	94616
	Hs	[kW]	80.00	117.26
		[BTU/h]	275214	403387
Net heating output	Hi	[kW]	66.80	99.02
		[kcal/h]	57452	85155
	Hs	[kW]	71.20	105.54
		[BTU/h]	244941	363048
Air output		[m ³ /h]	5500	
Fuel consumption		[kg/h]	6.330	9.278
Power supply	Phase		3	
	Voltage	[V]	400	
	Plug	[A]	15	
	Frequency	[Hz]	50	
Power consumption		[W]	1820	
Nozzle		[USgal/h]	2.00 – 80° / W	
Pump pressure		[bar]	8.5	12.5
Flue diameter		[mm]	150	
Tank capacity		[l]	135	
Noise level at 1 m		[dBA]	76	
Dimensions, L x W x H		[mm]	1918 x 731 x 1220	
Weight		[kg]	149	
Fuse		[A]	15	
Adjustment of combustion air flap		[N. °]	A = 5	

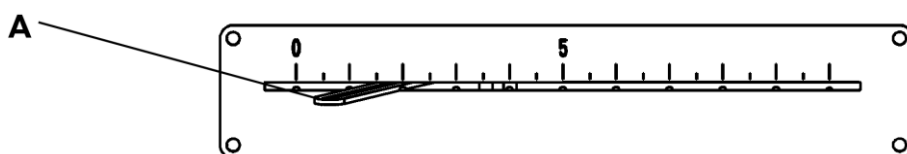

OPERATING DIAGRAM

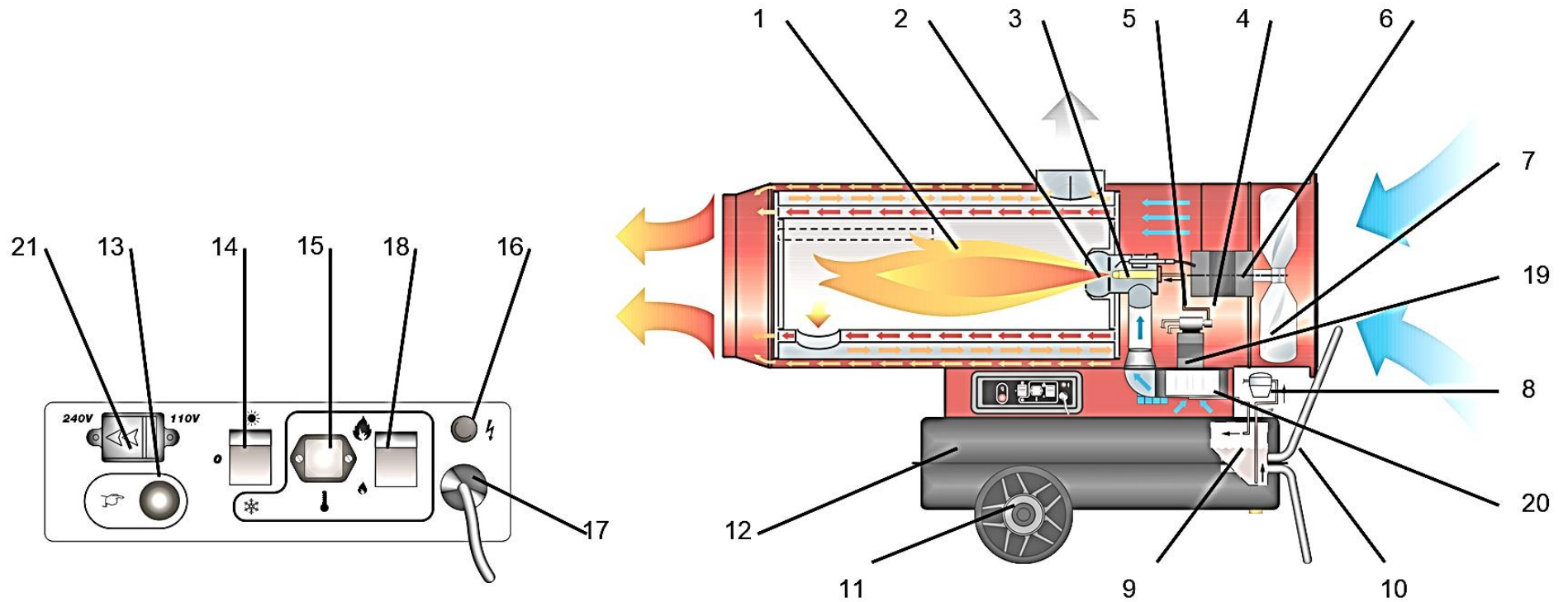

1 COMBUSTION CHAMBER
2 BURNER
3 NOZZLE
4 SOLENOID VALVE
5 DIESEL PUMP

6 FAN MOTOR
7 FAN
8 FUEL FILTER
9 FUEL CIRCUIT
10 SUPPORT/HANDLE

11 WHEEL
12 FUEL TANK
13 RESET BUTTON WITH CONTROL LAMP
14 MAIN SWITCH
15 ROOM THERMOSTAT PLUG

16 CONTROL LAMP
17 POWER CORD
18 HIGH-LOW THERMAL POWER SWITCH
19 BURNER MOTOR
20 AIR COMBUSTION ADJUSTMENT
21 INPUT VOLTAGE SWITCH

IMPORTANT

Before using the space heater, carefully read all of the instructions and follow them scrupulously.

The manufacturer cannot be held responsible for damage to persons and/or property caused by improper use of the equipment.

This instruction manual is an integral part of the equipment and must therefore be stored carefully and passed on with the unit in the event of a change of ownership.

GENERAL RECOMMENDATIONS

The space heaters run on diesel fuel. Direct combustion versions send hot air and combustion products into the room, while indirect combustion versions are fitted with a flue to discharge the fumes through the chimney.

Always follow local regulations and codes when using this heater:

- Follow the instructions in this booklet very carefully;
- Use only in places free of flammable vapours or high dust content;
- Keep inflammable material at a safe distance from the heater (minimum 3 metres);
- Make sure firefighting equipment is readily available;
- Ensure that the machine resting surface or ground is not made of flammable material;
- Make sure sufficient fresh outside air is provided according to the heater requirements. Direct combustion heaters should only be used in well vented areas in order to avoid carbon monoxide poisoning;
- The indirect combustion heater is installed near a chimney to take away the fumes (see the paragraph "FUMES FLUE POSITIONING DIAGRAM") and connected to an electrical switchboard;
- Make sure nothing is obstructing the aspiration and expulsion of air; movement of air may be obstructed in various ways including placing covers or other objects on the heater or positioning the heater too near a wall or other large object;
- In case of very low temperatures add kerosene to the heating oil;

- Make sure heater is always under surveillance and keep children and animals away from it;
- Before starting the heater always check free rotation of the fan.
- Unplug heater when not in use.

SAFETY DEVICES

The heater is fitted with an electronic device that controls the flame and the maximum safe temperature by means of a photocell, two overheat thermostats, and a fan start thermostat.

The electronic device controls start/stop times and trips the safety in case of malfunction. It has a reset button (13) that can assume different colours (Function Light) depending on the function mode:

- Steady green: heater functioning normally;
- Steady red: heater in safety stop;
- Flashing orange: heating interrupted due to excessive variations in voltage supply ($T < 175V$ or $T > 265V$); heating will resume automatically when voltage returns in range from 190 V and 250 V.

To restart heating after a safety stop, push reset button (13) for 3 seconds.

Warning

NEVER do more than two restarts in a row: uncombusted diesel fuel may accumulate in the combustion chamber and suddenly flare up at the next restart.

If the safety stop persists, you have to find and eliminate the cause of the stop before you restart the heater. Push button (13) for at least 5 seconds to launch a self-diagnosis programme, after which the button will assume

different colours (Self-diagnosis light) depending on the type of safety that tripped:

- Flashing orange: false flame detected during restart cycle.
- Flashing red: no flame during restart cycle.
- Flashing red/green: no flame during work cycle.
- Steady orange: internal error of electronic device.

Warning



See “TROUBLESHOOTING” to identify the cause of the malfunction.

OPERATION

Before switching on the heater and, therefore, before plugging it into the electrical power supply, check that the power supply specifications are the same as those stated on the identification plate.

Warning



- The power line must be earthed and fitted with a residual current circuit breaker.
- The heater plug must be inserted into a socket equipped with a mains switch.

The heater must be placed on a flat, stable, and levelled surface in order to prevent it from overturning and/or diesel leaks from the tank filler cap.

The heater can work in “ventilation” mode turning the switch (14) to  : the fan motor starts, while the burner is off.

The heater works in “heating” mode, turning the switch (14) to  : the burner motor start, immediately followed by ignition and combustion. When the combustion chamber becomes hot, the cooling fan motor starts.

To select the heating power level, turn the switch (18) to the position corresponding to the first stage (I S) or second stage (II S).

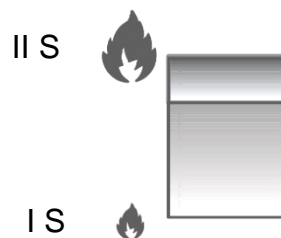

In heating mode the heater can run automatically when connected to a control device such as thermostat, time clock. Connection of control is made to connectors 2 and 3 of the plug (15) fitted to the heater after having removed the bridge between 2 and 3 as fitted ex works. This bridge should be kept and retrofitted if manual running of heater is wished at another time.

Warning



At the end of the start cycle, the electronic control device causes button (13) to flash briefly to confirm completion of the heater start cycle.

When unit is started for the first time or is started after the oil tank has been totally emptied, the diesel flow to the burner may be impaired by air in the circuit. In this case the control box will cut out the heater and it might be necessary to renew the starting procedure once by depressing the reset button (13).

If the heater does not function, the first things to do are:

1. Check that the tank still contains some diesel;
2. Push reset button (13);
3. If the heater still does not function, see “TROUBLESHOOTING” to identify the cause of the malfunction.

Warning



Never stop the machine by unplugging the electrical plug: this could cause overheating.

STOPPING THE HEATER

Set main switch (14) on “0” position or turn thermostat or other control device on lowest setting.

The flame goes out and the fan continues to work for approximately 90 sec. cooling the combustion chamber.

TRANSPORT

Warning



Before moving the heater:

- **Stop the heater as indicated in the “STOP” paragraph;**
- **Cut electrical power by removing the plug from the electrical socket;**
- **Wait until the heater cools.**

Before moving the heater, make sure the oil tank cap is securely attached.

Warning



Diesel may leak during handling and transport: the fuel tank cap is not sealed. This allows air to enter and allows the tank to be emptied while the heater is running.

The heater can be supplied in a mobile version (with wheels) or wall version mounted on a support structure with anchors for fastening by means of ropes or chains. To move the mobile version, just grip the heater by the support handle and roll it on the wheels. The second version must be lifted by using a lift truck or similar equipment.

In this case, make sure that the ropes and/or chains are securely attached and that they are in perfect condition before you start to move the heater.

MAINTENANCE

To ensure correct heater function, you have to clean the combustion chamber, burner, and fan at regular intervals.

Warning



Before starting any maintenance procedure, ALWAYS:

- **Stop the heater as indicated in the “STOP” paragraph;**
- **Cut electrical power by removing the plug from the electrical socket;**
- **Wait until the heater cools.**

Periodic maintenance of the heater is necessary to ensure proper performance and to prevent failures. To ensure correct heater function, the combustion chamber, burner, and fan must be cleaned at regular intervals by a qualified service technician. Maintenance should be performed at the following periodic intervals:

Daily maintenance (customer to perform)

- Inspect air inlet / air outlet and exhaust stack, remove debris if any
- If any air duct is installed, secure it is fixed. Minimize bends and keep ducts straight
- Verify fuel tank is full
- Verify that exhaust stack is properly installed

Weekly maintenance (customer to perform)

- Disassemble, inspect and clean fuel filter with clean fuel

Every 50 hours maintenance (qualified Spitwater service technician to carry out)

- Remove top cover and clean the motor, fan blade and the interior shell
- Inspect the fuel hose assembly and check for any leaks

Every six months maintenance (qualified Spitwater service technician to carry out)

- Disassemble burner head
 - Inspect and clean burner diffuser
 - Inspect and replace nozzle if necessary
 - Clean ignition electrodes and adjust settings
 - Check air combustion setting
- Check overheat thermostat
- Inspect and clean the combustion chamber
- Open electric board, inspect electrical components and check connections.

IP110

- Check fuel pressure setting of fuel pump
- Inspect and test the burner.

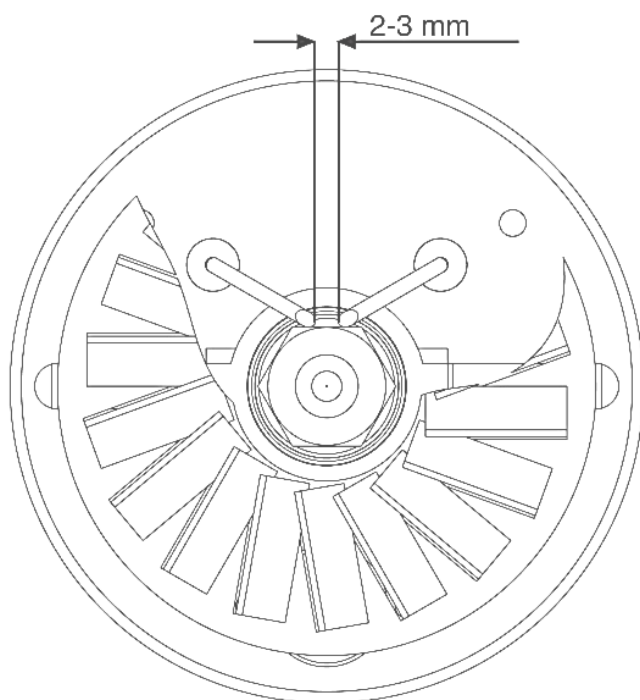

ASSEMBLY INSTRUCTIONS

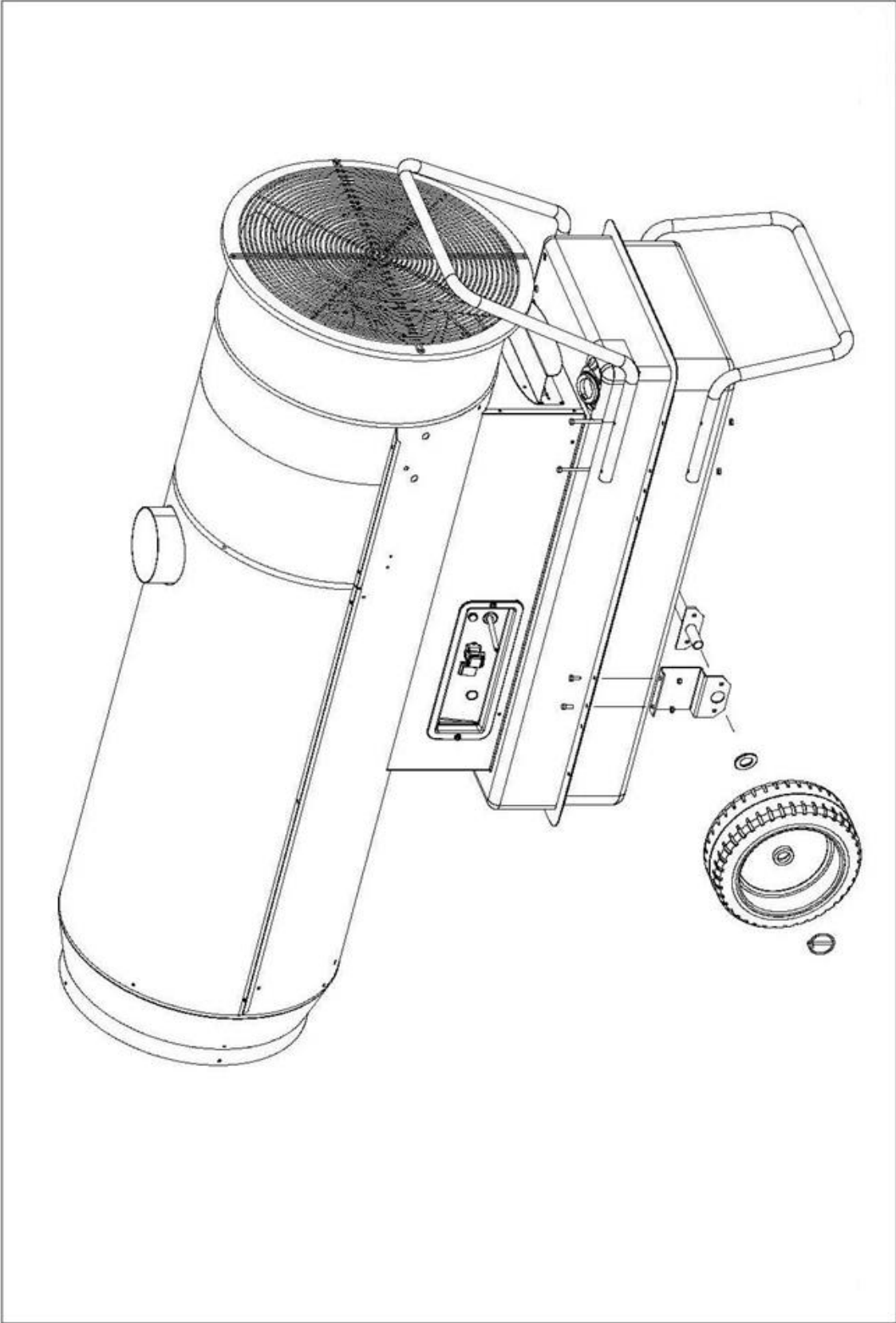

INSTALLATION GUIDE

RECOMMENDED CHIMNEY LAY-OUT

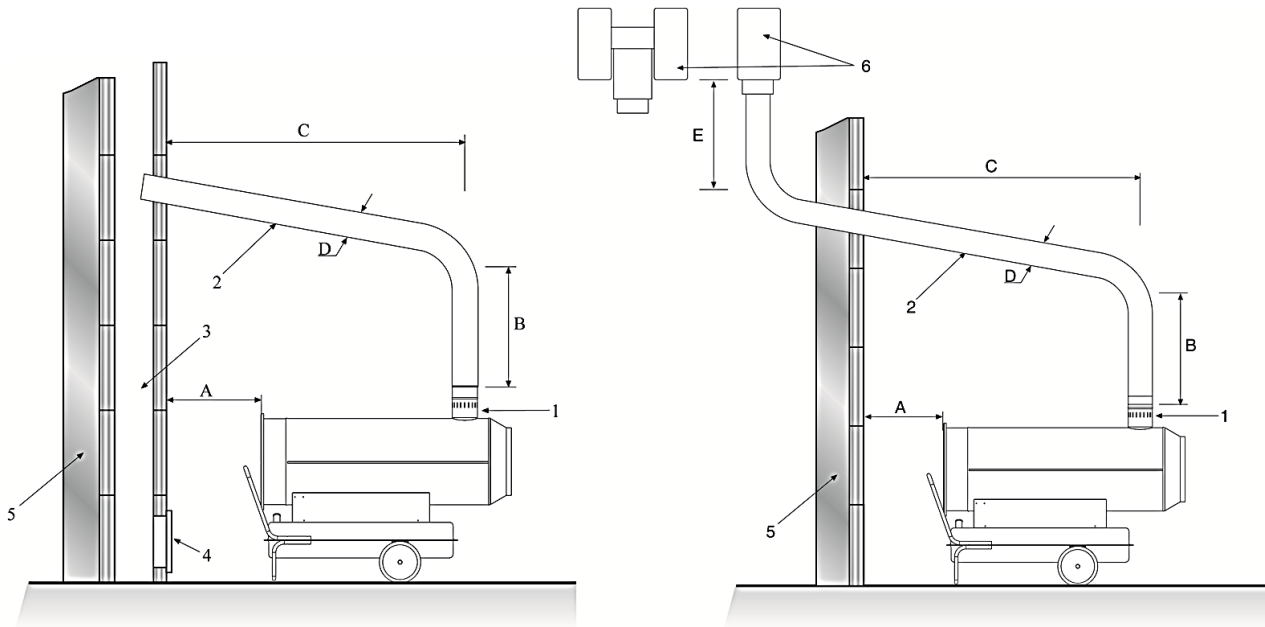

DESCRIPTION

- A) Minimum 1 m
- B) Minimum 1 m
- C) As short as possible
- D) Greater than or equal to diameter of heater smoke outlet
- E) Minimum 1 m

- 1) Anti-wind device provided with heater
- 2) Horizontal crossing with 5° minimum upward slope
- 3) Chimney with minimum internal dimensions 20 x 20 cm
- 4) Chimney anti-explosion inspection door
- 5) External buffer wall
- 6) Chimney draught H shape

N.B. The above recommendations are approximate. The chimney installation must comply with local regulations.

Attention: the anti-wind device (3) **MUST** be positioned as shown in the drawings on the left. Otherwise, the heater may not work or may present serious combustion problems.

TROUBLE SHOOTING

PROBLEM	RESET BUTTON (13)		CAUSE	REMEDY	
Motor does not start, no ignition	Off	-	Wrong setting of room thermostat or other control	Check correct setting of heater control. If thermostat, make sure selected temperature is higher than room temperature	
			Defective thermostat or other control	Contact authorised Spitwater service agent	
Fan does not start or stops during start-up or heating	Flashing orange	-	No electrical current	Check mains Check proper positioning and functioning of switch, If incorrect contact authorised Spitwater service agent	
			Possible electricity supply problem	Contact licenced electrician	
Fan stops during start-up or heating	Steady red	Flashing red or flashing red/green	Flashing orange	Presence of flame before transformer ignites Defective photocell	Contact authorised Spitwater service agent Contact authorised Spitwater service agent
			Flashing red or flashing red/green	Defective electrical motor	Contact authorised Spitwater service agent
				Defective electrical motor bearings	Contact authorised Spitwater service agent
				Burned out condenser	Contact authorised Spitwater service agent
				Defective electric ignitor	Contact authorised Spitwater service agent
				Defective flame control box	Contact authorised Spitwater service agent
				Defective photocell	Contact authorised Spitwater service agent
				Insufficient or no fuel at burner	Contact authorised Spitwater service agent
			Defective solenoid Defective electric ignitor	Contact authorised Spitwater service agent	
			Flashing orange	Internal error of electronic device	Contact authorised Spitwater service agent
Fan starts and flame lights, generating fumes	Steady green	-	Insufficient combustion air	Make sure air inlet and outlet are free Contact authorised Spitwater service agent	
			Excess combustion air	Contact authorised Spitwater service agent	
			Fuel contaminated or contains water	Contact authorised Spitwater service agent	
			Air leaks in fuel circuit	Check the seals on the ducts and the diesel filter	
			Insufficient fuel at burner	Contact authorised Spitwater service agent	
			Excess fuel at burner	Contact authorised Spitwater service agent	
Heater does not stop	Steady green	-	Defective solenoid seal	Contact authorised Spitwater service agent	
Fan (6) does not start or does not stop	Steady green	-	FA thermostat not working	Check the FA thermostat and its connections; replace if necessary	

If the heater is still not working properly, please contact your nearest authorized dealer.

WIRING DIAGRAM

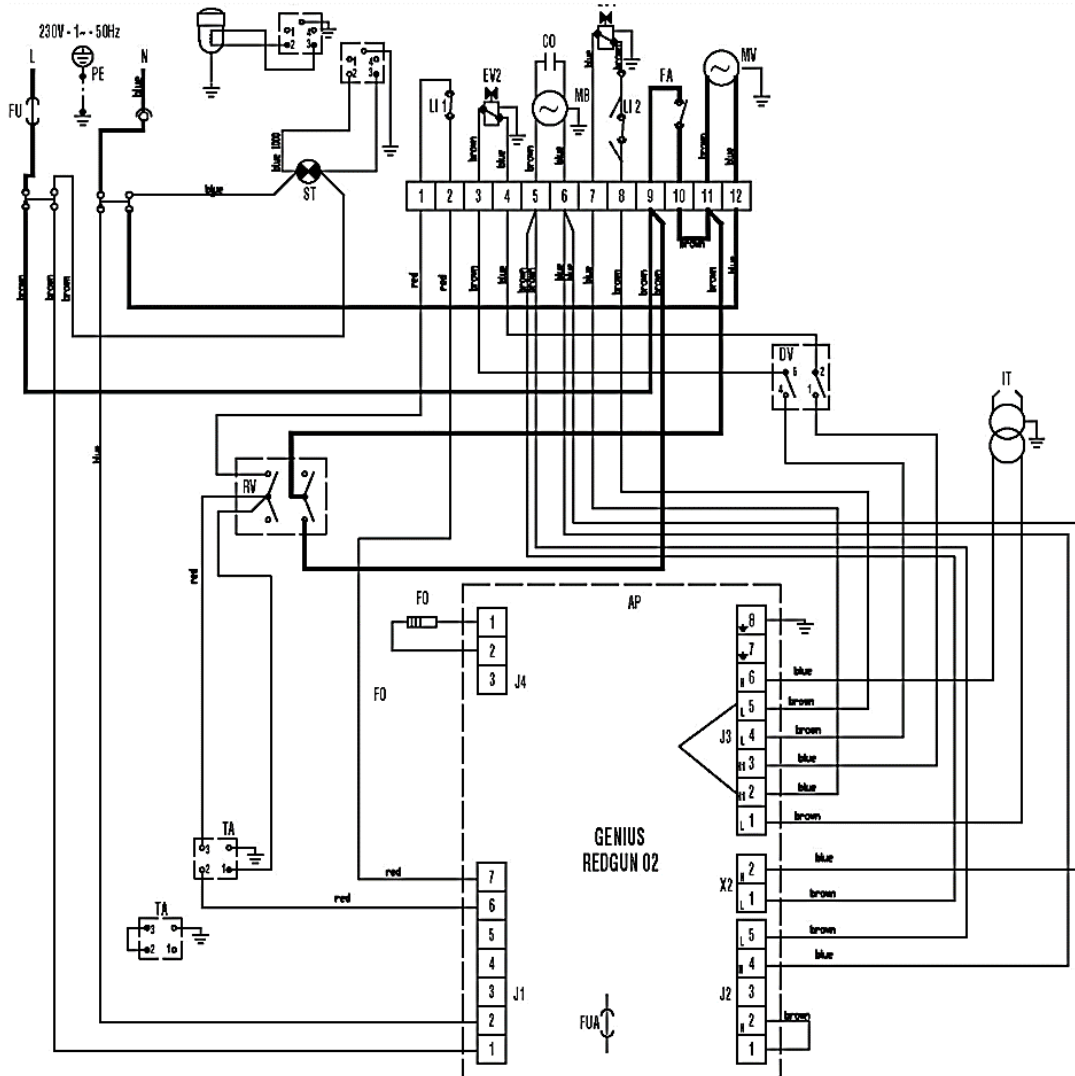

- | | |
|---------------------------------------|---|
| AP CONTROL BOX | FO PHOTOCELL |
| TA ROOM THERMOSTAT PLUG | MV FAN MOTOR |
| ST ELECTRIC PILOT LAMP | FUA FUSE |
| FU FUSE | RV CONTROL SWITCH |
| LI1 OVERHEAT THERMOSTAT | EV2 SOLENOID VALVE II° Stage |
| EV1 SOLENOID VALVE I° Stage | LF ANTI-JAMMING FILTER |
| MB BURNER MOTOR | TF PLUG OF PRE-HEATED FILTER |
| CO CAPACITOR | DV HIGH – LOW THERMAL POWER SWITCH |
| IT TRANSFORMER H.V. | RF HEAT FILTER |
| LI2 OVERHEAT SAFETY THERMOSTAT | FA FAN THERMOSTAT |
| | TD TRANSFORMER |